

MENIIT

NEET | IIT-JEE | FOUNDATION

Corporate Office: 44-A/1, Kalu Sarai, New Delhi 110016 | Web: www.meniit.com

JEE MAINS-2011

IMPORTANT INSTRUCTIONS

1. Immediately fill in the particulars on this page of the Test Booklet with **Blue/Black Ball Point Pen**. **Use of pencil is strictly prohibited.**
2. The Answer Sheet is kept inside this Test Booklet. When you are directed to open the Test Booklet, take out the Answer Sheet and fill in the particulars carefully.
3. The test is of **3** hours duration.
4. The Test Booklet consists of **90** questions. The maximum marks are **360**.
5. There are **three** parts in the question paper A, B, C consisting of **Chemistry, Physics and Mathematics** having 30 questions in each part of equal weightage. Each question is allotted **4 (four)** marks for each correct response.
6. Candidates will be awarded marks as stated above in instruction No.5 for correct response of each question. 1/4 (one fourth) marks will be deducted for indicating incorrect response of each question. No deduction from the total score will be made if no response is indicated for an item in the answer sheet.
7. There is only one correct response for each question. Filling up more than one response in each question will be treated as wrong response and marks for wrong response will be deducted accordingly as per instruction 6 above.
8. Use **Blue/Black Ball Point Pen only** for writing particulars/markings responses on **Side-1** and **Side-2** of the Answer Sheet. **Use of pencil is strictly prohibited.**
9. No candidate is allowed to carry any textual material, printed or written, bits of papers, pager, mobile phone, any electronic device, etc., except the Admit Card inside the examination hall/room.
10. Rough work is to be done on the space provided for this purpose in the Test Booklet only. This space is given at the bottom of each page and in **3** pages (Pages **21 – 23**) at the end of the booklet.
11. On completion of the test, the candidate must hand over the Answer Sheet to the Invigilator on duty in the Room/Hall. **However, the candidates are allowed to take away this Test Booklet with them.**
12. The CODE for this Booklet is **C**. Make sure that the CODE printed on **Side-2** of the Answer Sheet is the same as that on this booklet. In case of discrepancy, the candidate should immediately report the matter to the Invigilator for replacement of both the Test Booklet and the Answer Sheet.
13. **Do not fold or make any stray marks on the Answer Sheet.**

PART-A : CHEMISTRY

1. The presence or absence of hydroxy group on which carbon atom of sugar differentiates RNA and DNA?
 (1) 1st (2) 2nd (3) 3^{er} (4) 4th

Ans. [2]

Sol. RNA and DNA has ribose and deoxyribose sugars, which differs in absence of hydroxy group at 2nd carbon.

2. Among the following the maximum covalent character is shown by the compound

(1) Fe Cl₂ (2) Sn Cl₂ (3) AlCl₃ (4) MgCl₂

Ans. [3]

Sol. Covalent character in ionic compounds is governed by Fajan's Rule. AlCl₃ will show Maximum covalent character on account of higher polarising power of Al³⁺ because of its having higher positive charge and smaller size.

3. Which of the following statements is wrong ?

- (1) The stability of hydrides increases from NH₃ to BiH₃ in group 15 of the periodic table.
 (2) Nitrogen cannot form dπ – pπ bond.
 (3) Single N – N bond is weaker than the single P – P bond.
 (4) N₂O₄ has two resonance structures

Ans. [1]

Sol. The stability of hydrides decreases from NH₃ to BiH₃ which can be observed from their bond dissociation enthalpy. The correct order is NH₃ < PH₃ < AsH₃ < SbH₃ < BiH₃.

Property	NH ₃	PH ₃	AsH ₃	SbH ₃	BiH ₃
$\Delta_{\text{diss}}H^\ominus(\text{E-H}) / \text{kJ mol}^{-1}$	389	322	297	255	—

4. Phenol is heated with a solution of mixture of KBr and KBrO₃. The major product obtained in the above reaction is :

- (1) 2-Bromophenol (2) 3-Bromophenol (3) 4-Bromophenol (4) 2, 4, 6-Tribromophenol

Ans. [4]

Sol. $\text{KBr (aq.)} + \text{KBrO}_3 \text{ (aq.)} \longrightarrow \text{Br}_2 \text{ (aq.)}$

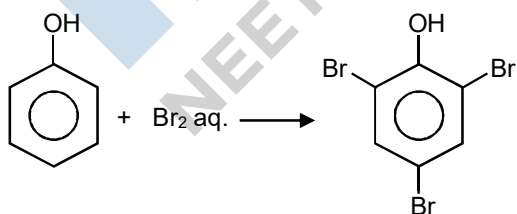

2, 4, 6-tribromophenol

5. A 5.2 molal aqueous solution of methyl alcohol, CH₃OH, is supplied. What is the mole fraction of methyl alcohol in the solution ?

- (1) 0.100 (2) 0.190 (3) 0.086 (4) 0.050

Ans. [3]

Sol. $X_{\text{ethyl alcohol}} = \frac{5.2}{5.2 + \frac{1000}{18}} = 0.086$

6. The hybridisation of orbitals of N atom in NO_3^- , NO_2^+ and NH_4^+ are respectively

- (1) sp, sp^2, sp^3 (2) sp^2, sp, sp^3 (3) sp, sp^3, sp^2 (4) sp^2, sp^3, sp

Ans. [2]

Sol. NO_2^+ Number of electron pairs = 2

Number of bond pairs = 2

Number of lone pair = 0

So, the species is linear with sp hybridisation.

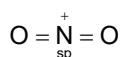

NO_3^- Number of electron pairs = 3

Number of bond pairs = 3

Number of lone pair = 0

So, the species is trigonal planar with sp^2 hybridisation.

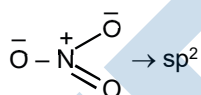

NH_4^+ Number of electron pairs = 4

Number of bond pairs = 4

Number of lone pair = 0

So, the species is tetrahedral with sp^3 hybridisation.

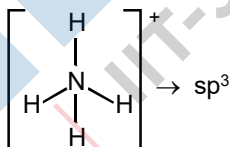

7. Ethylene glycol is used as an antifreeze in a cold climate. Mass of ethylene glycol which should be added to 4 kg of water to prevent it from freezing at -6°C will be (K_f for water = $1.86\text{ K kg mol}^{-1}$, and molar mass of ethylene glycol mol^{-1})

- (1) 804.32 g (2) 204.30 g (3) 400.00 g (4) 304.60 g

Ans. [1]

Sol. $\Delta T_f = iK_f m$

$\Delta T_f = 6^\circ\text{C}$

$i = 1$

Sol. As metallic character of element attached to oxygen atom increases, the difference between the electronegativity values of element and oxygen increases and thus basic character of oxides increases and vice-versa. Hence the increasing correct order of basic nature is $\text{Al}_2\text{O}_3 < \text{MgO} < \text{Na}_2\text{O} < \text{K}_2\text{O}$.

12. A gas absorbs a photon of 355 nm and emits at two wavelengths. If one of the emissions is at 680 nm, the other is at :

- (1) 1035 nm (2) 325 nm (3) 743 nm (4) 518 nm

Ans. [3]

Sol. $E = E_1 + E_2$

$$\frac{hc}{\lambda} = \frac{hc}{\lambda_1} + \frac{hc}{\lambda_2}$$

$$\frac{1}{\lambda} = \frac{1}{\lambda_1} + \frac{1}{\lambda_2}$$

$$\frac{1}{355} = \frac{1}{680} + \frac{1}{\lambda_2}$$

$$\lambda_2 = 742.76 \text{ nm.}$$

13. Which of the following statements regarding sulphur is incorrect ?

- (1) S_2 molecule is paramagnetic
 (2) The vapour at 200°C consists mostly
 (3) At 600°C the gas mainly consists of S_2 molecules
 (4) The oxidation state of sulphur is never less than + 4 in its compounds.

Ans. [4]

Sol. Sulphur exhibit + 2, + 4, + 6 oxidation states but + 4 and + 6 are more common.

14. The entropy change involved in the isothermal reversible expansion of 2 moles of an ideal gas from a volume of 10 dm^3 to a volume of 100 dm^3 at 27°C is

- (1) $38.3 \text{ J mol}^{-2} \text{ K}^{-1}$ (2) $35.8 \text{ J mol}^{-1} \text{ K}^{-1}$ (3) $32.3 \text{ J mol}^{-1} \text{ K}^{-1}$ (4) $42.3 \text{ J mol}^{-1} \text{ K}^{-1}$

Ans. [1]

Sol. $\Delta S = nR \ln \frac{V_2}{V_1}$

$$= 2.303nR \log \frac{V_2}{V_1}$$

$$= 2.303 \times 2 \times 8.314 \times \log \frac{100}{10}$$

$$= 38.3 \text{ J mol}^{-1} \text{ K}^{-1}$$

15. Which of the following facts about the complex $[\text{Cr}(\text{NH}_3)_6] \text{Cl}_3$ is wrong ?

- (1) The complex involves d^2sp^3 hybridisation and is octahedral in shape.
 (2) The complex is paramagnetic

- (3) The complex is an outer orbital complex.
 (4) The complex gives white precipitate with silver nitrate solution.

Ans. [3]

Sol. In case of d^3 configuration, the number of unpaired electrons remains 3 whether the ligand is strong field or weak field. The hybridisation scheme can be shown as follow :

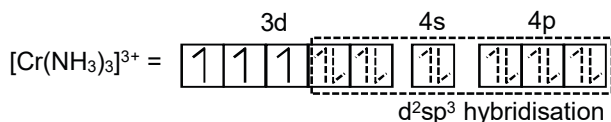

Hence the complex is inner orbital complex as it involves $(n - 1)$ d orbitals for hybridisation,
 $3.93 = \sqrt{n(n+2)}$; so $n = 3$ (here n is number of unpaired electron(s)).

16. The structure of IF_7 is

- (1) square pyramid (2) trigonal bipyramid (3) octahedral (4) pentagonal bipyramid

Ans. [4]

Sol. The structure is pentagonal bipyramid having sp^3d^3 hybridisation as given below :

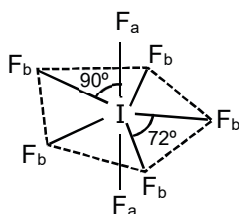

$$\text{F}_b - \text{I} - \text{F}_b = 72^\circ \text{ (5 number)} \quad ; \quad \text{F}_d - \text{I} - \text{F}_a = 90^\circ \text{ (10 number)}$$

$$\text{F}_b - \text{I} \text{ bond length} = 1.858 \pm 0.004 \text{ \AA} \quad ; \quad \text{F}_a - \text{I} \text{ bond length} = 1.786 \pm 0.007 \text{ \AA}.$$

17. The rate of a chemical reaction doubles for every 10°C rise of temperature. If the temperature is raised by 50°C , the rate of the reaction increase by about

- (1) 10 times (2) 24 times (3) 32 times (4) 64 times

Ans. [3]

Sol.
$$\frac{\text{Rate at } 50^\circ\text{C}}{\text{Rate at } T_1^\circ\text{C}} = (2)^{\frac{\Delta T}{T_1}} = (2)^{\frac{50}{10}} = 2^5$$

 = 32 times

18. The strongest acid amongst the following compounds is

- (1) CH_3COOH (2) HCOOH
 (3) $\text{CH}_3\text{CH}_2\text{CH}(\text{Cl})\text{CO}_2\text{H}$ (4) $\text{ClCH}_2\text{CH}_2\text{CH}_2\text{COOH}$

Ans. [3]

Sol. α -chlorobutyric acid is more stronger acid than others due to $-I$ effect of Cl.

19. Identify the compound that exhibits tautomerism.

- (1) 2-Butane (2) Lactic acid (3) 2-Pentanone (4) Phenol

Ans. [3]

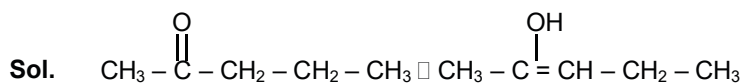

- 20.** A vessel at 1000 K contains CO_2 with a pressure of 0.5 atm. Some of the CO_2 is converted into CO on the addition of graphitic. If the total pressure at equilibrium is 0.8 atm, the value of K is :
- (1) 1.8 atm (2) 3 atm (3) 0.3 atm (4) 0.18 atm

Ans. [1]

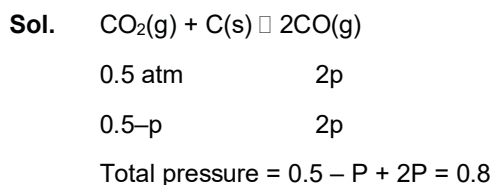

$$K_p = \frac{P_{\text{CO}}^2}{P_{\text{CO}_2}} = \frac{(2P)^2}{(0.5 - P)} = \frac{(0.6)^2}{(0.5 - 0.3)}$$

- 21.** In context of the lanthanoids, which of the following statements is not correct ?
- (1) There is gradual decrease in the radii of the members with increasing atomic number in the series.
 (2) All the members exhibit + 3 oxidation state.
 (3) Because of similar properties the separation of lanthanoids is not easy.
 (4) Availability of 4f electrons results in the formation of compounds in + 4 state for all the members of the series

Ans. [4]

Sol. Availability of 4f electrons donot results in the formation of compounds in +4 state for all the members of the series.

- 22.** a and b are van der Waal's constants for gases. Chlorine is more easily liquefied than ethane because :
- (1) a and b for $\text{Cl}_2 >$ a and b for C_2H_6
 (2) a and b for $\text{Cl}_2 <$ a and b C_2H_6
 (3) a for $\text{Cl}_2 <$ a for C_2H_6 but b for $\text{Cl}_2 >$ b for C_2H_6
 (4) a for $\text{Cl}_2 >$ a for C_2H_6 but b for $\text{Cl}_2 <$ b for C_2H_6

Ans. [4]

Sol.

	a	b
Cl_2	6.579 L ² bar mol ⁻²	0.05622 L mol ⁻¹
C_2H_6	5.562 L ² bar mol ⁻²	0.06380 L mol ⁻¹

- 23.** The magnetic moment (spin only) of $[\text{NiCl}_4]$ is :
- (1) 1.82 BM (2) 5.46 BM (3) 2.82 BM (4) 1.41 BM

Ans. [3]

Sol. In the paramagnetic and tetrahedral complex $[\text{NiCl}_4]^{2-}$, the nickel is in +2 oxidation state and the ion has the electronic configuration 3d8. The hybridisation scheme is as shown in figure.

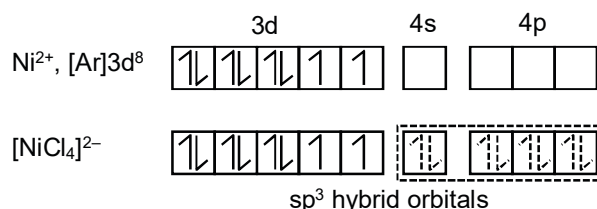

$$\mu_{B.M.} = \sqrt{n(n+2)} = \sqrt{2(2+2)} = \sqrt{8} = 2.82 \text{ BM}$$

24. In a face centered cubic lattice, atom A occupies the corner positions and atom B occupies the face centre positions. If one atom of B is missing from one of the face centered points, the formula of the compound is :

- (1) A_2B (2) AB_2 (3) A_2B_3 (4) A_2B_5

Ans. [4]

Sol. A B

$$8 \times \frac{1}{8} \qquad 5 \times \frac{1}{2}$$

Formula of compo A_2B_5 .

25. The outer electron configuration of Gd (Atomic N : 64) is :

- (1) $af^3 5d^5 6s^2$ (2) $4f^8 5d^0 6s^2$ (3) $4f^4 5d^4 6s^2$ (4) $4f^7 5d^1 6s^2$

Ans. [4]

Sol. Gadolinium (${}_{64}\text{Gd}$) = $[\text{Xe}]^{54} 4f^7 5d^1 6s^2$

26. Boron cannot form which one of the following anions ?

- (1) BF_6^{3-} (2) BH_4^- (3) $\text{B}(\text{OH})_4^-$ (4) BO_2^-

Ans. [1]

Sol. Due to non-availability of d-orbitals, boron is unable to expand its octet. Therefore, the maximum covalence of boron cannot exceed 4.

27. Ozonolysis of an organic compounds gives formaldehyde as one of the products. This confirms the presence of :

- (1) two ethylenic double bonds (2) a vinyl group
 (3) an isopropyl group (4) an acetylenic triple bond

Ans. [2]

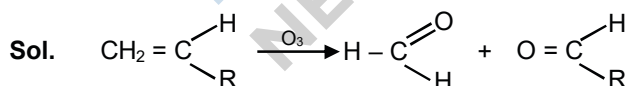

Presence of one vinyl group gives formaldehyde as one of the product in ozonolysis.

28. Sodium ethoxide has reacted with ethanoyl chloride. The compound that is produced in the above reaction is :

- (1) Diethyl ether (2) 2-Butanone (3) Ethyl chloride (4) Ethyl ethanoate

Ans. [4]

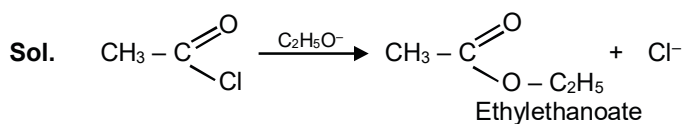

29. The degree of dissociation (α) of a weak electrolyte A_xB_y is related to van't Hoff factor (i) by the expression

(1) $\alpha = \frac{i-1}{(x+y-1)}$ (2) $\alpha = \frac{i-1}{x+y+1}$ (3) $\alpha = \frac{x+y-1}{i-1}$ (4) $\alpha = \frac{x+y+1}{i-1}$

Ans. [1]



$1 - \alpha \quad x\alpha \quad y\alpha$

$i = 1 - \alpha + x\alpha + y\alpha$

$i = 1 + \alpha(x + y - 1)$

$\alpha = \frac{i-1}{(x+y-1)}$

30. Silver Mirror test is given by which one of the following compounds ?

- (1) Acetaldehyde (2) Acetone (3) Formaldehyde (4) Benzophenone

Ans. [1, 3]

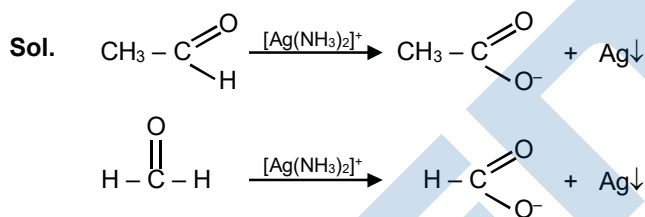

PART-B : PHYSICS

31. 100 g of water is heated from 30°C to 50°C. Ignoring the slight expansion of the water, the change in its internal energy is (specific heat of water is 4184 J/kg/K) :

- (1) 4.2 kJ (2) 8.4 kJ (3) 84 kJ (4) 2.1 kJ

Ans. [2]

Sol. $\Delta Q = M, S, \Delta T$

$$= 100 \times 10^{-3} \times 4.184 \times 20 = 8.4 \times 10^3$$

$$\Delta Q = 84 \text{ kJ}, \quad \Delta W = 0$$

$$\Delta Q = \Delta V + \Delta W$$

$$\therefore \Delta V = 8.4 \text{ kJ.} \quad \text{Ans.}$$

32. The half life of a radioactive substance is 20 minutes. The approximate time interval ($t_2 - t_1$) between the time t_2 when $\frac{2}{3}$ of it has decayed an time t_1 when $\frac{1}{3}$ of it had decayed is :

- (1) 7 min (2) 14 min (3*) 20 min (4) 28 min

Ans. [3]

Sol. $\frac{2}{3}N_0 = N_0 e^{-\lambda t_1}$

$$\frac{1}{3}N_0 = N_0 e^{-\lambda t_2}$$

$$2 = e^{\lambda(t_2 - t_1)}$$

$$\lambda(t_2 - t_1) = \ln 2$$

$$(t_2 - t_1) = \frac{\ln 2}{\lambda} = 20 \text{ min}$$

33. A mass M , attached to a horizontal spring, executes S.H.M. with amplitude A_1 . When the mass M passes through its mean position then a smaller mass m is placed over it and both of them move together with amplitude A_2 . The ratio of $\left(\frac{A_1}{A_2}\right)$ is :

- (1) $\frac{M}{M+m}$ (2) $\frac{M+m}{M}$ (3) $\left(\frac{M}{M+m}\right)^{1/2}$ (4) $\left(\frac{M+m}{M}\right)^{1/2}$

Ans. [4]

Sol. C.O.L.M.

$$MV_{\max} = (m + M)V_{\text{new}} \quad , \quad V_{\max} = A_1\omega_1$$

$$V_{\text{new}} = \frac{MV_{\max}}{(m + M)}$$

Now,

$$V_{\text{new}} = A_2\omega_2$$

$$\frac{M.A_1}{(m + M)}\sqrt{\frac{K}{M}} = A_2\sqrt{\frac{K}{(m + M)}}$$

$$A_2 = A_1 \sqrt{\frac{M}{m+M}} \quad \frac{A_1}{A_2} = \left(\frac{m+M}{M}\right)^{1/2} \text{ Ans.}$$

34. Energy required for the electron excitation in Li^{++} from the first to the third Bohr orbit is :
 (1) 12.1 eV (2) 36.3 eV (3*) 108.8 eV (4) 122.4 eV

Ans. [3]

Sol. $E_1 = -\frac{13.6(3)^2}{(1)^2}$

$$E_3 = -\frac{13.6(3)^2}{(3)^2}$$

$$\begin{aligned} \therefore \Delta E &= E_3 - E_1 \\ &= 13.6(3)^2 \left[1 - \frac{1}{9}\right] \\ &= \frac{13.6 \times 9 \times 8}{9} \end{aligned}$$

$\Delta E = 108.8 \text{ eV}$ Ans.

35. The transverse displacement $y(x, t)$ of a wave on a string is given by

$$y(x, t) = e^{-(ax^2 + bt^2 + 2\sqrt{ab}xt)}$$

- (1) wave moving in +x direction with speed (2) wave moving in -x direction with speed
 (3) standing wave of frequency (4) standing wave of frequency

Ans. [2]

Sol. $y(x, t) = e^{-[\sqrt{a}x + \sqrt{b}t]^2}$

It is transverse type $y(x, t) = e^{-(ax+bt)^2}$

$$\text{Speed } v = \frac{\sqrt{b}}{\sqrt{a}}$$

and wave is moving along -x direction.

36. A resistor 'R' and $2\mu\text{F}$ capacitor in series is connected through a switch to 200V direct supply. Across the capacitor is a neon bulb that lights up at 120 V. Calculate the value of R to make the bulb light up 5s after the switch has been closed. ($\log_{10} 2.5 = 0.4$)

- (1) $1.3 \times 10^4 \Omega$ (2) $1.7 \times 10^5 \Omega$ (3) $2.7 \times 10^6 \Omega$ (4) $3.3 \times 10^7 \Omega$

Ans. [3]

Sol. $v = 200(1 - e^{-t/\tau})$

$$120 = 200(1 - e^{-t/\tau})$$

$$e^{-t/\tau} = \frac{200 - 120}{200} = \frac{80}{200}$$

$$t/\tau = \log(2.5) = 0.4$$

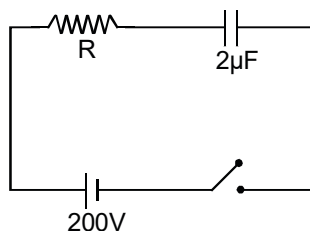

$$5 = (0.4) \times R \times 2 \times 10^{-6}$$

$$\Rightarrow R = \frac{5}{(0.4) \times 2 \times 10^{-6}}$$

$$= R = 2.7 \times 10^6$$

37. A current I flows an infinitely long wire with cross section in the form of a semi-circular ring of radius R . The magnitude of the magnetic induction along its axis is :

- (1) $\frac{\mu_0 I}{\pi^2 R}$ (2) $\frac{\mu_0 I}{2\pi^2 R}$ (3) $\frac{\mu_0 I}{2\pi R}$ (4) $\frac{\mu_0 I}{4\pi R}$

Ans. [1]

Sol. $v = \frac{I}{\pi R}$

$$dB = \left(\frac{\mu_0}{4\pi}\right) \frac{2I}{R} \quad I = \lambda R d\theta$$

$$\begin{aligned} \therefore B &= \int_{-\pi/2}^{\pi/2} dB \cos \theta \\ &= \frac{\mu_0 \lambda}{2\pi} \int_{-\pi/2}^{\pi/2} \cos \theta d\theta \\ &= \frac{\mu_0 \lambda}{\pi} = \frac{\mu_0 I}{\pi^2 R} \quad \text{Ans.} \end{aligned}$$

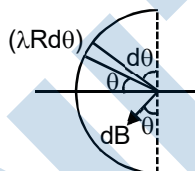

38. A Carnot engine operating between temperatures T_1 and T_2 has efficiency $\frac{1}{6}$. When T_2 is lowered by 62 K ; its efficiency increases to $\frac{1}{3}$. Then T_1 and T_2 are respectively :

- (1) 372 K and 310 K (2) 372 K and 330 K (3) 330 K and 268 K (4) 310 K and 248 K

Ans. [1]

Sol. $\eta = 1 - \frac{T_2}{T_1} = \frac{1}{6} \Rightarrow \frac{T_2}{T_1} = 1 - \frac{1}{6} = \frac{5}{6}$

$$\frac{1}{3} = 1 - \frac{(T_2 - 62)}{T_1} \Rightarrow \frac{T_2 - 62}{T_1} = \frac{2}{3}$$

$$\frac{5(T_2 - 62)}{T_2} = \frac{2}{3}$$

$$5T_2 - 310 = 4T_2$$

$$T_2 = 310 \quad \text{and} \quad T_1 = \frac{6 \times 310}{5}$$

$$T_1 = 372 \text{ K} \quad \text{Ans.}$$

39. An object, moving with a speed of 6.25 m/s, is decelerated at a rate given by

$$\frac{dv}{dt} = -2.5\sqrt{v}$$

where v is the instantaneous speed. The time taken by the object, to come to rest, would be :

- (1) 1s (2) 2s (3) 4s (4) 8s

Ans. [2]

Sol. $\int_{6.25}^0 \frac{dv}{\sqrt{v}} = -2.5 \int_0^t dt$

$$2\sqrt{v} \Big|_{6.25}^0 = -2.5t$$

$$2\sqrt{6.25} = 2.5t$$

$$t = 2 \text{ sec.}$$

Ans.

40. The electrostatic potential inside a charged spherical ball is given by $\phi = ar^2 + b$ where r is the distance from the centre ; a, b are constant. Then the charge density inside the ball is :

- (1) $-24\pi a\epsilon_0 r$ (2) $-6 a\epsilon_0 r$ (3) $-24\pi a\epsilon_0$ (4) $-6 a\epsilon_0$

Ans. [4]

Sol. $\phi = ar^2 + b$

$$E = -\frac{d\phi}{dr} = -2ar$$

$$\oint \vec{E} \cdot d\vec{s} = \frac{q}{\epsilon_0}$$

$$-2ar \cdot 4\pi r^2 = \frac{q}{\epsilon_0}$$

$$q = -8 \epsilon_0 a \pi r^3$$

$$\rho = \frac{q}{\frac{4}{3}\pi r^3}$$

$$\rho = -6a\epsilon_0 \text{ Ans.}$$



41. A car is fitted with a convex side-view mirror of focal length 20 cm. A second car 2.8 m behind the first car is overtaking the first car at a relative speed of 15 m/s. The speed of the image of the second car as seen in the mirror of the first one is :

- (1) $\frac{1}{10}$ m/s (2) $\frac{1}{15}$ m/s (3) 10 m/s (4) 15 m/s

Ans. [2]

Sol. Mirror formula :

$$\frac{1}{v} + \frac{1}{-280} = \frac{1}{20}$$

$$\frac{1}{v} + \frac{1}{20} = \frac{1}{280}$$

$$\frac{1}{v} + \frac{14+1}{280}$$

$$v = \frac{280}{15}$$

$$v_I = -\left(\frac{v}{u}\right)^2 \cdot v_{cm}$$

$$\therefore v_I = -\left(\frac{280}{15 \times 280}\right)^2 \cdot 15$$

$$\therefore v_I = \frac{-15}{15 \times 15}$$

$$v_I = -\frac{1}{15} \text{ m/s} \quad \text{Ans.}$$

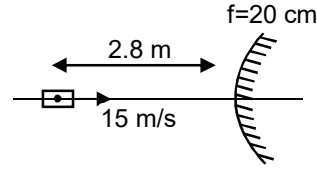

42. If a wire is stretched to make it 0.1% longer, its resistance will :

- (1) increase by 0.05%
- (2) increase by 0.2%
- (3) decrease by 0.2%
- (4) decrease by 0.05%

Ans. [2]

Sol. $R = \frac{\rho \ell}{A}$ ($\because V = A\ell$ const.)

$V = A\ell$

By differentiation $0 = \ell dA + Ad\ell$ (1)

By differentiation $dR = \frac{\rho(Ad\ell - \ell dA)}{A^2}$ (2)

$\frac{dR}{R} = \frac{2\rho d\ell}{A}$ or

$\frac{dR}{R} = 2 \frac{d\ell}{\ell}$

So, $\frac{dR}{R} \% = 2 \frac{d\ell}{\ell} \% = 2 \times 0.1\%$

$\frac{dR}{R} \% = 0.2\%$ **Ans.**

43. Three perfect gases at absolute temperatures T_1 , T_2 and T_3 are mixed. The masses of molecules are m_1 , m_2 and m_3 and the number of molecules are n_1 , n_2 and n_3 respectively. Assuming no loss of energy, the final temperature of the mixture is :

(1) $\frac{(T_1 + T_2 + T_3)}{3}$

(2) $\frac{n_1 T_1 + n_2 T_2 + n_3 T_3}{n_1 + n_2 + n_3}$

(3) $\frac{n_1 T_1^2 + n_2 T_2^2 + n_3 T_3^2}{n_1 T_1 + n_2 T_2 + n_3 T_3}$

(4) $\frac{n_1^2 T_1^2 + n_2^2 T_2^2 + n_3^2 T_3^2}{n_1 T_1 + n_2 T_2 + n_3 T_3}$

Ans. [2]

Sol. $T = \frac{n_1 T_1 + n_2 T_2 + n_3 T_3}{n_1 + n_2 + n_3}$ **Ans.**

44. Two identical charged spheres suspended from a common point by two massless strings of length ℓ are initially a distance d ($d \ll \ell$) apart because of their mutual repulsion. The charge begins to leak from both the spheres at a constant rate. As a result the charges approach each other with a velocity v . Then as a function of distance x between them,

- (1) $v \propto x^{-1/2}$ (2) $v \propto x^{-1}$ (3) $v \propto x^{1/2}$ (4) $v \propto x$

Ans. [1]

Sol. $\sin \theta = \frac{kq^2}{d^2}$
 $\cos \theta = mg$
 $\tan \theta = \frac{k}{mg} \cdot \frac{q^2}{x^2}$
 $\frac{x}{2\ell} = \frac{k}{mg} \cdot \frac{q^2}{x^2}$
 $x^3 = \frac{2k\ell}{mg} q^2$

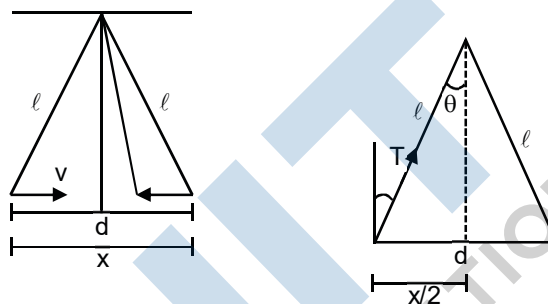

$q^2 \propto x^3$
 $q^2 \propto x^{3/2}$
 $\frac{dq}{dt} \propto \frac{3}{2} x^{1/2} \frac{dx}{dt}$ (dq/dt is constant)
 $c \propto x^{1/2} v$
 $v \propto x^{-1/2}$

45. Work done in increasing the size of a soap bubble from a radius of 3 cm to 5 cm is nearly (surface tension of soap solution = 0.03 Nm^{-1}):

- (1) $4 \pi \text{ mJ}$ (2) $0.2 \pi \text{ mJ}$ (3) $2 \pi \text{ mJ}$ (4) $0.4 \pi \text{ mJ}$

Ans. [4]

Sol. $W = T \Delta A$
 $= 0.03 (2 \times 4\pi \times (5^2 - 3^2)) 10^{-4}$
 $= 24\pi (16) \times 10^{-6}$
 $= 0.384 \pi \times 10^{-3} \text{ Joule}$
 $\cong 0.4 \pi \text{ mJ}$ **Ans.**

46. A fully charged capacitor C with initial charge q_0 is connected to a coil of self inductance L at $t = 0$. The time at which the energy is stored equally between the electric and magnetic fields is :

- (1) $\pi\sqrt{LC}$ (2) $\frac{\pi}{4}\sqrt{LC}$ (3) $2\pi\sqrt{LC}$ (4) \sqrt{LC}

Ans. [2]

Sol. In LC oscillation energy is transferred C to L

or L to C maximum energy in L is $= \frac{1}{2}LI_{\max}^2$

Maximum energy in C is $= \frac{q_{\max}^2}{2C}$

Equal energy will be when

$$\frac{1}{2}LI^2 = \frac{1}{2} \frac{1}{2}LI_{\max}^2$$

$$I = \frac{1}{\sqrt{2}}I_{\max}$$

$$I = I_{\max} \sin \omega t = \frac{1}{\sqrt{2}}I_{\max}$$

$$\omega t = \frac{\pi}{4}$$

or $\frac{2\pi}{T}t = \frac{\pi}{4}$ or $t = \frac{\pi}{8}$

$$t = \frac{\pi}{8}2\pi\sqrt{LC} = \frac{\pi}{4}\sqrt{LC}$$

Ans.

47. Two bodies of masses m and $4m$ are placed at a distance r . The gravitational potential at a point on the line joining them where the gravitational field is zero is :

- (1) zero (2) $-\frac{4Gm}{r}$ (3) $-\frac{6Gm}{r}$ (4) $-\frac{9Gm}{r}$

Ans. [4]

Sol. $\frac{Gm}{x^2} = \frac{G(4m)}{(r-x)^2}$

$$\frac{1}{x} = \frac{2}{r-x}$$

$$r-x = 2x$$

$$3x = \frac{r}{3}$$

$$x = \frac{r}{3}$$

$$\frac{Gm}{r/3} - \frac{G(4m)}{2r/3}$$

$$\frac{3Gm}{r} - \frac{6Gm}{r} = \frac{9Gm}{r} \quad \text{Ans.}$$

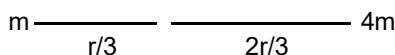

Ans. [2]

Sol. $x_1 = A \sin(\omega t + \phi_1)$

$x_2 = A \sin(\omega t + \phi_2)$

$x_1 - x_2 = A \left[2 \sin \left[\omega t + \frac{\phi_1 + \phi_2}{2} \right] \sin \left[\frac{\phi_1 - \phi_2}{2} \right] \right]$

$A = 2A \sin \left(\frac{\phi_1 - \phi_2}{2} \right)$

$\frac{\phi_1 - \phi_2}{2} = \frac{\pi}{6}$

$\phi_1 = \frac{\pi}{3}$

Ans.

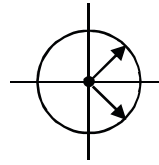

51. Direction :

The question has a paragraph followed by two statements, **Statement-1** and **Statement-2**. Of the given four alternatives after the statements, choose the one that describes the statements.

A thin air film is formed by putting the convex surface of a plane-convex lens over a plane glass plate. With monochromatic light, this film gives an interference pattern due to light reflected from the top (Convex) surface and the bottom (glass plate) surface of the film.

Statement-1 : When light reflects from the air-glass plate interface, the reflected wave suffers a phase change of π

Statement-2 : The centre of the interference pattern is dark.

- (1) Statement-1 is true, Statement-2 is false
- (2) Statement-1 is true, Statement-2 is true and Statement -2 is the correct explanation of Statement-1.
- (3) Statement-1 is true, Statement-2 is true and Statement-2 is **not** the correct explanation of Statement-1
- (4) Statement-1 is false, Statement-2 is true.

Ans. [3]

Sol. S_1 :When light reflects from deuser med. (Glass) a phase difft of π is generated.

S_2 : Centre maxima or minima depends on thickness of the lens.

52. The thermally insulated vessel contains an ideal gas of molecular mass M and ratio of specific heat γ . It is moving with speed v and is suddenly brought to rest. Assuming no heat is lost to the surroundings, its temperature increases by :

(1) $\frac{(\gamma - 1)}{2(\gamma + 1)R} Mv^2K$

(2) $\frac{(\gamma - 1)}{2\gamma R} Mv^2K$

(3) $\frac{\gamma Mv^2}{2R} K$

(4) $\frac{(\gamma - 1)}{2R} Mv^2 K$

Ans. [4]

Sol. $\frac{1}{2} Mv^2 = C_v \cdot \Delta T$

$$\frac{1}{2}Mv^2 = \frac{R}{\gamma - 1} \Delta T$$

$$\Delta T = \frac{Mv^2(\gamma - 1)}{2R} = \frac{(\gamma - 1)Mv^2}{2R}$$

53. A screw gauge gives the following reading when used to measure the diameter of a wire.

Main scale reading : 0 mm.

Circular scale reading : 52 divisions

Given that 1 mm on main scale corresponds to 100 divisions of the circular scale. The diameter of wire from the above data is :

- (1) 0.52 cm (2) 0.052 cm (3) 0.026 cm (4) 0.005 cm

Ans. [2]

Sol. Least count of screw gauge = $\frac{1}{100}$ mm = 0.01 mm

Diameter = Divisions on circular scale \times least count + main scale reading

$$= 52 \times \frac{1}{100} + 0$$

$$= 0.52 \text{ mm}$$

$$\text{diameter} = 0.052 \text{ cm}$$

54. A boat is moving due east in a region where the earth's magnetic field is $5.0 \times 10^{-5} \text{ NA}^{-1} \text{ m}^{-1}$ due north and horizontal. The boat carries a vertical aerial 2m long. If the speed of the boat is 1.50 ms^{-1} , the magnitude of the induced emf in the wire of aerial is :

- (1) 1 mV (2) 0.75 mV (3) 0.50 mV (4) 0.15 mV

Ans. [4]

Sol. Find = $B \times v \times \ell$

$$= 5.0 \times 10^{-5} \times 1.50 \times 2$$

$$= 10.0 \times 10^{-5} \times 1.5$$

$$= 15 \times 10^{-5} \text{ vot.}$$

$$= 0.15 \text{ mV}$$

55. This question has Statement-1 and Statement-2. Of the four choices given after the statements, choose the one that best describes the two statements.

Statement-1 : Sky wave signals are used for long distance radio communication. These signals are in general, less stable than ground wave signals.

Statement -2 : The state of ionosphere varies from hour to hour, day to day and season to season.

- (1) Statement-1 is true, Statement-2 is false
 (2) Statement-1 is true, Statement-2 is true and Statement-2 is the correct explanation of Statement-1.
 (3) Statement-1 is true, Statement-2 is true and Statement-2 is **not** the correct explanation of Statement-1
 (4) Statement-1 is false, Statement-2 is true.

Ans. [2]

56. A mass m hangs with the help of a string wrapped around a pulley on a frictionless bearing. The pulley has mass m and radius R . Assuming pulley to be a perfect uniform circular disc, the acceleration of the mass m , if the string does not slip on the pulley, is :

- (1) $\frac{3}{2}g$ (2) g (3) $\frac{2}{3}g$ (4) $\frac{g}{3}$

Ans. [3]

Sol. $mg - T = ma$

$$TR = \frac{mR^2\alpha}{2}$$

$$T = \frac{mR\alpha}{2} = \frac{ma}{2}$$

$$mg - \frac{ma}{2} = ma$$

$$\frac{3ma}{2} = mg$$

$$a = \frac{2g}{3} \quad \text{Ans.}$$

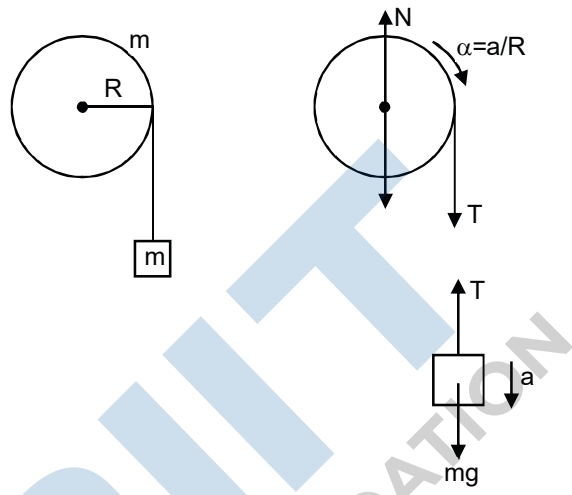

57. A water fountain on the ground sprinkles water all around it. If the speed of water coming out of the fountain is v , the total area around the fountain that gets wet is :

- (1) $\pi \frac{v^2}{g}$ (2) $\pi \frac{v^4}{g^2}$ (3) $\frac{\pi v^4}{2 g^2}$ (4) $\pi \frac{v^2}{g^2}$

Ans. [2]

Sol. $R_{\max} = \frac{v^2}{g} \sin 2\theta = \frac{v^2}{g}$

$$\text{area} = \pi R^2$$

$$= \pi \frac{v^4}{g^2} \quad \text{Ans.}$$

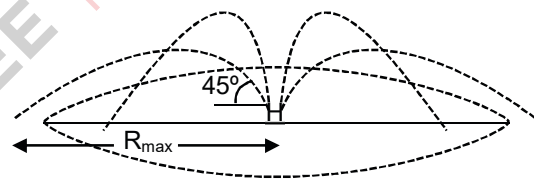

58. This question has Statement-1 and Statement-2. Of the four choices given after the statements, choose the one that best describes the two statements.

Statement-1 : A metallic surface is irradiated by a monochromatic light of frequency $\nu > \nu_0$ (the threshold frequency). The maximum kinetic energy and the stopping potential are K_{\max} and V_0 respectively. If the frequency incident on the surface is doubled, both the K_{\max} and V_0 are also doubled.

Statement -2 : The maximum kinetic energy and the stopping potential of photoelectrons emitted from a surface are linearly dependent on the frequency of incident light.

- (1) Statement-1 is true, Statement-2 is false
 (2) Statement-1 is true, Statement-2 is true and Statement-2 is the correct explanation of Statement-1.

(3) Statement-1 is true, Statement-2 is true and Statement-2 is **not** the correct explanation of Statement-1

(4) Statement-1 is false, Statement-2 is true.

Ans. [4]

Sol. $h\nu = h\nu_0 + k_{\max}$

$$k_{\max} = h\nu - h\nu_0$$

59. A pulley of radius 2m is rotated about its axis by a force $F = (20t - 5t^2)$ newton (where t is measured in seconds) applied tangentially. If the moment of inertia of the pulley about its axis of rotation is 10 kg m^2 , the number of rotations made by the pulley before its direction of motion if reversed, is :

(1) less than 3

(2) more than 3 but less than 6

(3) more than 6 but less than 9

(4) more than 9

Ans. [2]

Sol. To reverse the direction $\int \tau d\theta = 0$ (work done is zero)

$$\tau = (20t - 5t^2) \cdot 2 = 40t - 10t^2$$

$$\alpha = \frac{\tau}{I} = \frac{40t - 10t^2}{10} = 4t - t^2$$

$$\omega = \int_0^t \alpha dt = 2t^2 - \frac{t^3}{3}$$

ω is zero at

$$2t^2 - \frac{t^3}{3} = 0$$

$$t^3 = 6t^2$$

$$t = 6 \text{ sec.}$$

$$\theta = \int \omega dt$$

$$= \int_0^6 \left(2t^2 - \frac{t^3}{3} \right) dt$$

$$\left[\frac{2t^3}{3} - \frac{t^4}{12} \right]_0^6 = 216 \left[\frac{2}{3} - \frac{1}{3} \right] = 36 \text{ rad.}$$

No. of revolution $\frac{36}{2\pi}$ Less than 6

60. Water is flowing continuously from a tap having an internal diameter $8 \times 10^{-3} \text{ m}$. The water velocity as it leaves the tap is 0.4 ms^{-1} . The diameter of the water stream at a distance $2 \times 10^{-1} \text{ m}$ below the tap is close to :

(1) $5.0 \times 10^{-3} \text{ m}$

(2) $7.5 \times 10^{-3} \text{ m}$

(3) $9.6 \times 10^{-3} \text{ m}$

(4) $3.6 \times 10^{-3} \text{ m}$

Ans. [4]

Sol. Diameter = $8 \times 10^{-3} \text{ m}$

$$v = 0.4 \text{ m/s}$$

$$v = \sqrt{u^2 + 2gh}$$

$$= \sqrt{(0.4)^2 + 2 \times 10 \times 0.2}$$

$$= 2 \text{ m/s}$$

$$A_1 v_1 = A_2 v_2$$

$$\pi \left(\frac{8 \times 10^{-3}}{4} \right)^2 \times 0.4 = \pi \times \frac{d^2}{4} \times 2$$

$$d \approx 3.6 \times 10^{-3} \text{ m}$$

MENIIT
NEET | IIT-JEE | FOUNDATION

PART-C : MATHEMATICS

61. Let α, β be real and z be complex number. If $z^2 + \alpha z + \beta = 0$ has two distinct roots on the line $\text{Re } z = 1$, then it is necessary that :

- (1) $\beta \in (0, 1)$ (2) $\beta \in (-1, 0)$ (3) $|\beta| = 1$ (4) $\beta \in (1, \infty)$

Ans. [4]

Sol. Let roots be $p + iq$ and $p - iq$ $p, q \in \mathbb{R}$

root lie on line $\text{Re}(z) = 1$

$\Rightarrow p = 1$

product of roots = $p^2 + q^2 = \beta = 1 + q^2$

$\Rightarrow \beta \in (1, \infty), (q \neq 0, \because \text{roots are distinct})$

62. The value of $\int_0^1 \frac{8 \log(1+x)}{1+x^2} dx$ is :

- (1) $\pi \log 2$ (2) $\frac{\pi}{8} \log 2$ (3) $\frac{\pi}{2} \log 2$ (4) $\log 2$

Ans. [1]

Sol. $x = \tan \theta$

$dx = \sec^2 \theta d\theta$

$I = \int_0^{\pi/4} \frac{8 \ln(1 + \tan \theta)}{\sec^2 \theta} \sec^2 \theta d\theta = 8 \int_0^{\pi/4} \ln(1 + \tan \theta) d\theta$

$\Rightarrow I = 8 \int_0^{\pi/4} \ln(1 + \tan(\pi/4 - \theta)) d\theta$

$= 8 \int_0^{\pi/4} \ln\left(\frac{2}{1 + \tan \theta}\right) d\theta$

$\Rightarrow 2I = 8 \int_0^{\pi/4} \ln(2) d\theta$

$= 8 \frac{\pi}{4} \ln 2 = 2\pi \ln 2$

$\Rightarrow I = \pi \ln 2$ **Ans.**

63. $\frac{d^2x}{dy^2}$ equals :

- (1) $\left(\frac{d^2y}{dx^2}\right)^{-1}$ (2) $-\left(\frac{d^2y}{dx^2}\right)^{-1} \left(\frac{dy}{dx}\right)^{-3}$ (3) $\left(\frac{d^2y}{dx^2}\right) \left(\frac{dy}{dx}\right)^{-2}$ (4) $-\left(\frac{d^2y}{dx^2}\right) \left(\frac{dy}{dx}\right)^{-3}$

Ans. [4]

Sol. $\frac{dy}{dx} = \frac{1}{\frac{dx}{dy}}$

$$\frac{d^2y}{dx^2} = \frac{d}{dx} \left(\frac{1}{\frac{dx}{dy}} \right) = \frac{d}{dy} \left(\frac{1}{\frac{dx}{dy}} \right) \frac{dy}{dx} = -\frac{1}{\left(\frac{dx}{dy}\right)^2} \cdot \frac{\frac{d^2x}{dy^2}}{\frac{dx}{dy}} = -\frac{d^2x}{\left(\frac{dx}{dy}\right)^3}$$

64. Let I be the purchase value of an equipment and V(t) be the value after it has been used for t years. The value V(t) depreciates at a rate given by differential equation $\frac{dV(t)}{dt} = -k(T - t)$, where k > 0 is a constant and T is the total life in years of the equipment. Then the scrap value V(T) of the equipment is :

- (1) $T^2 - \frac{I}{k}$ (2) $I - \frac{kT^2}{2}$ (3) $I - \frac{k(T-t)^2}{2}$ (4) $e - kT$

Ans. [2]

Sol. $\frac{dV(t)}{dt} = k(T - t)$

$$\int dV(t) = \int (-kT)dt + \int kt dt$$

$$V(t) = -kTt + k\frac{t^2}{2} + c$$

at t = 0 C = I

$$V(T) = -kT^2 + \frac{kt^2}{2} + I$$

Now at t = T

$$V(T) = -kT^2 + k\frac{T^2}{2} + I$$

$$V(T) = I - \frac{1}{2}kT^2$$

65. The coefficient of x^7 in the expansion of $(1 - x - x^2 + x^3)^6$ is :

- (1) 144 (2) -132 (3) -144 (4) 132

Ans. [3]

Sol. $(1 - x - x^2 + x^3)^6$

$$(1 - x)^6 (1 - x^2)^6$$

$$({}^6C_0 - {}^6C_1x^1 + {}^6C_2x^2 - {}^6C_3x^3 + {}^6C_4x^4 - {}^6C_5x^5 + {}^6C_6x^6) ({}^6C_0 - {}^6C_1x^2 + {}^6C_2x^4 - {}^6C_3x^6 + {}^6C_4x^8 + \dots + {}^6C_6x^{12})$$

Now coefficient of $x^7 = {}^6C_1 {}^6C_3 - {}^6C_3 {}^6C_2 + {}^6C_5 {}^6C_1$

$$= 6 \times 20 - 20 \times 15 + 36$$

$$= 120 - 300 + 36$$

$$= 156 - 300$$

$$= -144 \text{ Ans.}$$

66. For $x \in \left(0, \frac{5\pi}{2}\right)$, define $f(x) = \int_0^x \sqrt{t} \sin t dt$. Then f has

- (1) local maximum at π and 2π
- (2) local maximum at π and 2π
- (3) local maximum at π and local maximum at 2π
- (4) local maximum at π and local minimum at 2π

Ans. [4]

Sol. $f(x) = \int_0^x \sqrt{t} \sin t dt$

$f'(x) = \sqrt{x} \sin x$

local maximum at π

and local minimum at 2π **Ans.**

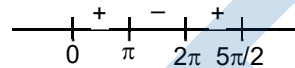

67. The area of the region enclosed by the curves $y = x$, $x = e$, $y = 1/x$ and the positive x-axis is :

- (1) 1/2 square units
- (2) 1 square units
- (3) 3/2 square units
- (4) 5/2 square units

Ans. [3]

Sol. Required area

= OAB + ACDB

= $\frac{1}{2} \times 1 \times 1 + \int_1^e \frac{1}{x} dx$

= $\frac{1}{2} + (\ln x)_1^e$

= $\frac{3}{2}$ square unit **Ans.**

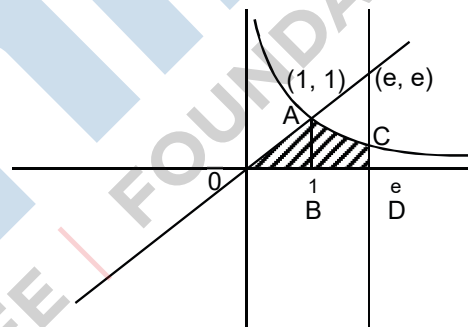

68. The lines $L_1 : y - x = 0$ and $L_2 : 2x + y = 0$ intersect the line $L_3 : y + 2 = 0$ at P and Q respectively. The bisector of the acute between L_1 and L_2 intersects L_3 at R.

Statement-1 : The ratio PR : RQ equals $2\sqrt{2} : \sqrt{5}$

Statement -2 : In any triangle, bisector of an angle divides the triangle into two similar triangle.

- (1) Statement-1 is true, Statement-2 is true and Statement-2 is the correct explanation of Statement-1.
- (2) Statement-1 is true, Statement-2 is false and Statement-2 is **not** the correct explanation of Statement-1
- (3) Statement-1 is true, Statement-2 is false

(4) Statement-1 is false, Statement-2 is true.

Ans. [3]

Sol.

∴ AD : DB = $2\sqrt{2} : \sqrt{5}$
 ∴ OD is angle bisector of angle AOB
 ∴ St : 1 true
 St : 2 false (obvious) **Ans.**

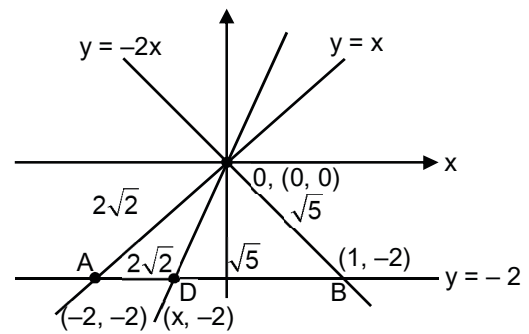

69. The value of p and q for which the function $f(x) = \begin{cases} \frac{\sin(p+1)x + \sin x}{x}, & x < 0 \\ q, & x = 0 \\ \frac{\sqrt{x+x^2} - \sqrt{x}}{x^{3/2}}, & x > 0 \end{cases}$ is continuous for all x in R,

are:

- (1) $p = \frac{1}{2}, q = -\frac{3}{2}$ (2) $p = \frac{5}{2}, q = \frac{1}{2}$ (3) $p = -\frac{3}{2}, q = \frac{1}{2}$ (4) $p = \frac{1}{2}, q = \frac{3}{2}$

Ans. [3]

Sol. $f(0) = q$

$$f(0^+) = \lim_{x \rightarrow 0^+} \frac{(1+x)^{1/2} - 1}{x} = \lim_{x \rightarrow 0^+} \frac{1 + \frac{1}{2}x + \dots - 1}{x} = \frac{1}{2}$$

$$f(0^-) = \lim_{x \rightarrow 0^-} \frac{\sin(p+1)x + \sin x}{x}$$

$$f(0^-) = \lim_{x \rightarrow 0^-} \frac{(\cos(p+1)x)(p+1) + (\cos x)}{1}$$

$$= (p+1) + 1 = p+2$$

∴ $p+2 = q = \frac{1}{2} \Rightarrow p = -\frac{3}{2}, q = \frac{1}{2}$ **Ans.**

70. If the angle between the line $x = \frac{y-1}{2} = \frac{z-3}{\lambda}$ and the plane $x + 2y + 3z = 4$ is $\cos^{-1} \left(\sqrt{\frac{5}{14}} \right)$, then λ

equals :

- (1) 2/3 (2) 3/2 (3) 2/5 (4) 5/2

Ans. [1]

Sol. $\frac{x-0}{1} = \frac{y-1}{2} = \frac{z-3}{\lambda}$ (1)

$x + 2y + 3z = 4$ (2)

Angle between the line and plane is

$$\cos(90 - \theta) = \frac{a_1 a_2 + b_1 b_2 + c_1 c_2}{\sqrt{a_1^2 + b_1^2 + c_1^2} \sqrt{a_2^2 + b_2^2 + c_2^2}}$$

$$\Rightarrow \sin \theta = \frac{1 + 4 + 3\lambda}{\sqrt{14} \times \sqrt{5 + \lambda^2}} = \frac{5 + 3\lambda}{\sqrt{14} \times \sqrt{5 + \lambda^2}} \dots(3)$$

But given that angle between line and plane is

$$\theta = \cos^{-1}\left(\frac{\sqrt{5}}{\sqrt{14}}\right) = \sin^{-1}\left(\frac{3}{\sqrt{14}}\right)$$

$$\Rightarrow \sin \theta = \frac{3}{\sqrt{14}}$$

∴ from (3)

$$\frac{3}{\sqrt{14}} = \frac{5 + 3\lambda}{\sqrt{14} \times \sqrt{5 + \lambda^2}}$$

$$\Rightarrow 9(5 + \lambda^2) = 25 + 9\lambda^2 + 30\lambda$$

$$\Rightarrow 30\lambda = 20$$

$$\lambda = \frac{2}{3}$$

Ans.

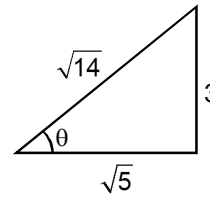

71. The domain of the function $f(x) = \frac{1}{\sqrt{|x| - x}}$ is :

- (1) $(-\infty, \infty)$ (2) $(0, \infty)$ (3) $(-\infty, 0)$ (4) $(-\infty, \infty) - \{0\}$

Ans. [3]

Sol. $f(x) = \frac{1}{\sqrt{|x| - x}}$

$$|x| - x > 0$$

$$|x| > x$$

$$\Rightarrow x < 0$$

$$\therefore x \in (-\infty, 0) \text{ Ans.}$$

72. The shortest distance between line $y - x = 1$ and curve $x = y^2$ is :

- (1) $\frac{\sqrt{3}}{4}$ (2) $\frac{3\sqrt{2}}{8}$ (3) $\frac{8}{3\sqrt{2}}$ (4) $\frac{4}{\sqrt{3}}$

Ans. [2]

Sol. $y - x = 1$

$$y^2 = x$$

$$2y \frac{dy}{dx} = 1$$

$$\frac{dy}{dx} = \frac{1}{2y} = 1$$

$$y = \frac{1}{2}$$

$$x = \frac{1}{4}$$

tangent at $\left(\frac{1}{4}, \frac{1}{2}\right)$

$$\frac{1}{2}y = \frac{1}{2}\left(x + \frac{1}{4}\right)$$

$$y = x + \frac{1}{4}$$

$$y - x = \frac{1}{4}$$

$$\text{distance} = \left| \frac{1 - \frac{1}{4}}{\sqrt{2}} \right| = \frac{3}{4\sqrt{2}} = \frac{3\sqrt{2}}{8} \quad \text{Ans.}$$

73. A man saves Rs. 200 in each of the first three months of his service. In each of the subsequent months of his service. In each of the subsequent months his saving increases by Rs. 40 more than the saving of immediately previous month. His total saving from the start of service will be Rs. 11040 after.

(1) 18 months (2) 19 months (3) 20 months (4) 21 months

Ans. [4]

Sol. a = Rs. 200

d = Rs. 40

savings in first two months = Rs. 400

remained savings = 200 + 240 + 280 + upto n terms

$$= \frac{n}{2} [400 + (n-1)40] = 11040 - 400$$

$$200n + 20n^2 - 20n = 10640$$

$$20n^2 + 180n - 10640 = 0$$

$$n^2 + 9n - 532 = 0$$

$$(n+28)(n-19) = 0$$

$$n = 19$$

∴ no. of months = 19 + 2 = 21 .

74. Consider the following statements

P : Suman is brilliant

Q : Suman is rich

R : Suman is honest

The negation of the statement "Suman is brilliant and dishonest if and only if Suman is rich" can be expressed as :

- (1) $\sim P \wedge (Q \leftrightarrow R)$ (2) $\sim (Q \leftrightarrow (P \wedge \sim R))$ (3) $\sim Q \leftrightarrow \sim P \wedge$ (4) $\sim (P \wedge \sim R) \leftrightarrow Q$

Ans. [2,4]

Sol. Negation of $(P \wedge \sim R) \leftrightarrow Q$ is $\sim ((P \wedge \sim R) \leftrightarrow Q)$

It may also be written as $\sim (Q \leftrightarrow (P \wedge \sim R))$

75. If $\omega (\neq 1)$ is a cube root of unit, and $(1 + \omega)^7 = A + B\omega$. Then (A, B) equals :

- (1) (0, 1) (2) (1, 1) (3) (2, 0) (4) (-1, 1)

Ans. [2]

Sol. $(1 + \omega)^7 = A + B\omega$

$$(-\omega^2)^7 = A + B\omega$$

$$-\omega^{14} = A + B\omega$$

$$-\omega^2 = A + B\omega$$

$$1 + \omega = A + B\omega$$

$$\therefore (A, B) = (1, 1)$$

76. If $\vec{a} = \frac{1}{\sqrt{10}}(3\hat{i} + \hat{k})$ and $\vec{b} = \frac{1}{7}(2\hat{i} + 3\hat{j} - 6\hat{k})$, then the value of $(2\vec{a} - \vec{b}) \cdot [(\vec{a} \times \vec{b}) \times (\vec{a} + 2\vec{b})]$ is :

- (1) -5 (2) -3 (3) 5 (4) 3

Ans. [1]

Sol. $(2\vec{a} - \vec{b}) \cdot [(\vec{a} \times \vec{b}) \times (\vec{a} + 2\vec{b})]$
 $= -(2\vec{a} - \vec{b}) \cdot [(\vec{a} \times 2\vec{b}) \times (\vec{a} + \vec{b})]$
 $= -(2\vec{a} - \vec{b}) \cdot [((\vec{a} \times 2\vec{b}) \cdot \vec{b})\vec{a} - ((\vec{a} + 2\vec{b}) \cdot \vec{a})\vec{b}]$
 $= -(2\vec{a} - \vec{b}) \cdot [((\vec{a} \cdot \vec{b}) + 2\vec{b} \cdot \vec{b})\vec{a} - ((\vec{a} \cdot \vec{a} + 2\vec{b} \cdot \vec{a})\vec{b})]$
 $= -(2\vec{a} - \vec{b}) \cdot [0 + 2\vec{a} - (0 + \vec{b})]$
 $= -(2\vec{a} - \vec{b}) \cdot (2\vec{a} - \vec{b})$
 $= -(2\vec{a} - \vec{b})^2 = -4\vec{a}^2 + 4\vec{a} \cdot \vec{b} - \vec{b}^2$
 $= -4 + 0 - 1 = -5$

77. If $\frac{dy}{dx} = y + 3 > 0$ and $y(0) = 2$, then $y(\ln 2)$ is equal to :

- (1) 7 (2) 5 (3) 13 (4) -2

Ans. [1]

Sol. $\frac{dy}{dx} = y + 3$

$$\frac{dy}{y+3} = dx$$

$$\ln(y + 3) = x + c$$

given at $x = 0, y = 2$

$$\ln 5 = c$$

$$\therefore \ln(y + 3) = x + \ln 5$$

$$\ln\left(\frac{y+3}{5}\right) = x$$

$$y + 3 = 5e^x$$

$$y + 5e^x - 3$$

$$\therefore y(\ln 2) = 5e^{\ln 2} - 3 = 7 \quad \text{Ans.}$$

78. Equation of the ellipse whose axis are the axis of coordinates and which passes through the point

$(-3, 1)$ and has eccentricity $\sqrt{\frac{2}{5}}$ is :

(1) $3x^2 + 5y^2 - 32 = 0$

(2) $5x^2 + 3y^2 - 48 = 0$

(3) $3x^2 + 5y^2 - 15 = 0$

(4) $5x^2 + 3y^2 - 32 = 0$

Ans. [1,2]

Sol. $\frac{x^2}{a^2} + \frac{y^2}{b^2} = 1$

$$\frac{9}{a^2} + \frac{1}{b^2} = 1 \quad \dots(1)$$

case - 1 when $a > b$

$$b^2 = a^2(1 - e^2)$$

$$b^2 = a^2(1 - 2/5)$$

$$5b^2 = 3a^2 \quad \dots(2)$$

from (1) & (2)

$$\frac{9 \times 3}{5b^2} + \frac{1}{b^2} = 1 \Rightarrow b^2 = \frac{32}{5}$$

$$\therefore a^2 = \frac{32}{3}$$

$$\therefore \frac{3x^2}{32} + \frac{5y^2}{32} = 1 \Rightarrow 3x^2 + 5y^2 - 32 = 0 \quad \text{Ans.}$$

case - 2 when $b > a$

$$a^2 = b^2(1 - e^2)$$

(4) Statement-1 is false, Statement-2 is true.

Ans. [1]

Sol. Statement - 1 :

$$\begin{aligned} B_1 + B_2 + B_3 + B_4 &= 10 \\ &= \text{coefficient of } x^{10} \text{ in } (x^1 + x^2 + \dots + x^7)^4 \\ &= \text{coefficient of } x^6 \text{ in } (1 - x^7)^4 (1 - x)^{-4} \\ &= {}^{4+6-1}C_6 = {}^9C_3 \end{aligned}$$

Statement - 2 :

Obviously 9C_3

82. Let R be the set of real numbers.

Statement-1 : $A = \{(x, y) \in R \times R : y - x \text{ is an integer}\}$ is an equivalence relation on R.

Statement-2 : $B = \{(x, y) \in R \times R : x = \alpha y \text{ for some rational number } \alpha\}$ is an equivalence relation on R.

- (1) Statement-1 is true, Statement-2 is true and Statement-2 is the correct explanation of Statement-1.
 (2) Statement-1 is true, Statement-2 is false and Statement-2 is **not** the correct explanation of Statement-1
 (3) Statement-1 is true, Statement-2 is false
 (4) Statement-1 is false, Statement-2 is true.

Ans. [3]

Sol. Statement - 1 :

- (i) $x - x$ is an integer $\forall x \in R$ so A is reflexive relation.
 (ii) $y - x \in I \Rightarrow x - y \in I$ so A is symmetric relation.
 (iii) $y - x \in I$ and $z - y \in I \Rightarrow y - x + z - y \in I$
 $\Rightarrow z - x \in I$ so A is transitive relation.

Therefore A is equivalence relation.

Statement - 2 :

- (i) $x = \alpha x$ when $\alpha = 1 \Rightarrow B$ is reflexive relation
 (ii) for $x = 0$ and $y = 2$, we have $0 = \alpha(2)$ for $\alpha = 0$
 But $2 = \alpha(0)$ for no α
 so B is not symmetric so not equivalence.

83. Consider 5 independent Bernoulli's trials each with probability of success p. If the probability of at least one failure is greater than or equal to $\frac{31}{32}$, then p lies in the interval :

- (1) $\left[\frac{1}{2}, \frac{3}{4}\right]$ (2) $\left[\frac{3}{4}, \frac{11}{12}\right]$ (3) $\left[0, \frac{1}{2}\right]$ (4) $\left[\frac{11}{12}, 1\right]$

Ans. [3]

Sol. $1 - P^5 \geq \frac{31}{32}$

$$P^5 \leq \frac{1}{32}$$

$$P \leq \frac{1}{2}$$

$$P \in \left[0, \frac{1}{2}\right]$$

84. The two circles $x^2 + y^2 = ax$ and $x^2 + y^2 = c^2$ ($c > 0$) touch each other if

- (1) $2|a| = c$ (2) $|a| = c$ (3) $a = 2c$ (4) $|a| = 2c$

Ans. [2]

Sol. $x^2 + y^2 = ax$ (1)

$$\Rightarrow \text{centre } c_1 \left(-\frac{a}{2}, 0\right) \text{ and radius } r_1 = \left|\frac{a}{2}\right|$$

$$x^2 + y^2 = c^2$$
 (2)

$$\Rightarrow \text{centre } c_2 (0, 0) \text{ and radius } r_2 = c$$

both touch each other iff

$$|c_1 c_2| = r_1 \pm r_2$$

$$\frac{a^2}{4} = \left(\pm \frac{a}{2} \pm c\right)^2 \Rightarrow \frac{a^2}{4} = \frac{a^2}{4} \pm |a|c + c^2 \Rightarrow |a| = c$$

85. Let A and B be two symmetric matrices of order 3.

Statement-1 : A(BA) and (AB)A are symmetric matrices.

Statement-2 : AB is symmetric matrix if matrix multiplication of A with B is commutative.

- (1) Statement-1 is true, Statement-2 is true and Statement-2 is the correct explanation of Statement-1.
 (2) Statement-1 is true, Statement-2 is false and Statement-2 is **not** the correct explanation of Statement-1
 (3) Statement-1 is true, Statement-2 is false
 (4) Statement-1 is false, Statement-2 is true.

Ans. [2]

Sol. $A' = A, B' = A$

$$P = A(BA)$$

$$P' = (A(BA))'$$

$$= (BA)' A'$$

$$= (A'B') A'$$

$$= (AB) A$$

$$= A(BA)$$

∴ A(BA) is symmetric

similarly (AB) A is symmetric

Statement (2) is correct but not correct explanation of statement (1).

86. If C and D are two events such that $C \subset D$ and $P(D) \neq 0$, then the correct statement among the following is :

(1) $P(C | D) = P(C)$ (2) $P(C | D) \geq P(C)$ (3) $P(C | D) < P(C)$ (4) $P(C | D) = \frac{P(D)}{P(C)}$

Ans. [2]

Sol. $P\left(\frac{C}{D}\right) = \frac{P(C \cap D)}{P(D)} = \frac{P(C)}{P(D)}$

$$\frac{1}{P(D)} \geq 1$$

$$\frac{P(C)}{P(D)} \geq P(C)$$

$$P(C) \leq P\left(\frac{C}{D}\right)$$

87. The vectors \vec{a} and \vec{b} are not perpendicular and \vec{c} and \vec{d} are two vector satisfying :

$\vec{b} \times \vec{c} = \vec{b} \times \vec{d}$ and $\vec{a} \cdot \vec{d} = 0$. Then the vector \vec{d} is equal to :

(1) $\vec{b} - \left(\frac{\vec{b} \cdot \vec{c}}{\vec{a} \cdot \vec{b}}\right) \vec{c}$ (2) $\vec{c} + \left(\frac{\vec{a} \cdot \vec{c}}{\vec{a} \cdot \vec{b}}\right) \vec{b}$ (3) $\vec{b} + \left(\frac{\vec{b} \cdot \vec{c}}{\vec{a} \cdot \vec{b}}\right) \vec{c}$ (4) $\vec{c} - \left(\frac{\vec{a} \cdot \vec{c}}{\vec{a} \cdot \vec{b}}\right) \vec{b}$

Ans. [4]

Sol. $\vec{a} \cdot \vec{b} \neq 0, \vec{b} \times \vec{c} = \vec{b} \times \vec{d}, \vec{a} \cdot \vec{d} = 0$

$$(\vec{b} \times \vec{c}) \times \vec{a} = (\vec{b} \times \vec{d}) \times \vec{a}$$

$$(\vec{b} \cdot \vec{a}) \vec{c} - (\vec{c} \cdot \vec{a}) \vec{b} = (\vec{b} \cdot \vec{a}) \vec{d} - (\vec{d} \cdot \vec{a}) \vec{b}$$

$$\vec{d} = \vec{c} - \left(\frac{\vec{a} \cdot \vec{c}}{\vec{a} \cdot \vec{b}}\right) \vec{b}$$

88. **Statement-1** : The point A(1, 0, 7) is the mirror image of the point B (1, 6, 3) in the line $\frac{x}{1} = \frac{y-1}{2} = \frac{z-2}{3}$

Statement 2 : The line : $\frac{x}{1} = \frac{y-1}{2} = \frac{z-2}{3}$ bisects the line segment joining A(1, 0, 7) and B(1, 6, 3).

- (1) Statement-1 is true, Statement-2 is true and Statement-2 is the correct explanation of Statement-1.
 (2) Statement-1 is true, Statement-2 is false and Statement-2 is **not** the correct explanation of Statement-1
 (3) Statement-1 is true, Statement-2 is false

(4) Statement-1 is false, Statement-2 is true.

Ans. [2]

Sol. Mid- point of AB \equiv M(1,3,5)

M lies on line

Direction ratios of AB is $\langle 0, 6, -4 \rangle$

Direction ratios of given line is $\langle 1, 2, 3 \rangle$

As AB is perpendicular to line

$$\therefore 0 \cdot 1 + 6 \cdot 2 - 4 \cdot 3 = 0$$

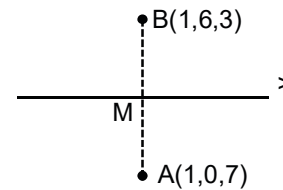

89. If $A = \sin^2 x + \cos^4 x$, then for all real x :

(1) $\frac{3}{4} \leq A \leq 1$

(2) $\frac{13}{16} \leq A \leq 1$

(3) $1 \leq A \leq 2$

(4) $\frac{3}{4} \leq A \leq \frac{13}{16}$

Ans. [1]

Sol. $A = \sin^2 x + \cos^4 x$

$$= \sin^2 x + (1 - \sin^2 x)^2$$

$$= \sin^4 x - \sin^2 x + 1$$

$$= \left(\sin^2 x - \frac{1}{2} \right)^2 + \frac{3}{4}$$

$$= \frac{3}{4} \leq A \leq 1$$

90. The number of values of k for which the linear equations

$$4x + ky + 2z = 0$$

$$kx + 4y + z = 0$$

$$2x + 2y + z = 0$$

posses a non-zero solution is :

(1) 3

(2) 2

(3) 1

(4) zero

Ans. [2]

Sol. $\Delta = \begin{vmatrix} 4 & k & 2 \\ k & 4 & 1 \\ 2 & 2 & 1 \end{vmatrix} = 0$

$$\Rightarrow 8 - k(k - 2) - 2(2k - 8) = 0$$

$$\Rightarrow 8 - k^2 + 2k - 4k + 16 = 0$$

$$\Rightarrow -k^2 - 2k + 24 = 0$$

$$\Rightarrow k^2 + 2k - 24 = 0$$

$$\Rightarrow (k + 6)(k - 4) = 0$$

$$\Rightarrow k = -6, 4$$

Number of values of k is 2